



- Blanket & Fluid Warming Cabinets
- IV Stands
- Surgical Scrub Sinks
- Case Carts
- Stainless Steel & Instrument Tables
- Prep Stands/Utility Tables
- Mayo Stands
- Ring Stands
- Stretchers
- Stainless Steel Cabinetry
- Kick Buckets
- and more...



Visit www.MacMedical.com or call us toll free at 1-877-828-9975.

ABOUT MAC MEDICAL

MAC Medical, Inc. concentrates in manufacturing the highest quality healthcare equipment available. Utilizing state of the art equipment such as a 3D CAD solid modeling system, a fully automated punch press line and highly skilled craftsman make it possible to produce equipment unparalleled in the marketplace.

Products include Blanket and Fluid Warming Cabinets, Surgical Scrub Sinks, Transport and Eye Stretchers, Stainless Steel Instrument and Back Tables, Case Carts, Stainless Steel Storage Cabinets, Nurses Documentation Stations, Sterile Process Sinks, Tables and extends to a full line of custom stainless products. Our customers' needs are our first priority.

TABLE OF CONTENTS

Blanket & Fluid Warming Cabinets	2-6
Surgical Scrub Sinks.....	7-11
Stretchers.....	12-13
Tables (Instrument Tables, Back Tables, Prep Stands/Utility Tables, Sterile Process Tables and Work Tables)	14-15
Case Carts	16-17
Processing Sinks.....	18-19
Stainless Steel Cabinetry.....	20-22
Mayo Stands	23
Ring Stands	24
IV Stands and Kick Buckets	25
Linen Hampers	26



BLANKET & FLUID WARMING CABINETS

MAC Medical, Inc. offers a variety of Blanket and Fluid Warming Cabinets. As with all of our products, warming cabinets undergo stringent testing procedures during the manufacturing process to assure a long life, the highest quality and accurate temperature settings. We offer standard sizes along with custom sizes to meet specific requirements.

Standard Features

- Keyed temperature lock out
- Push button digital operation
- Large dual digital displays
- Displays actual temperature and set point at all times
- Separate digitally controlled heating chambers
- Rapid warm time (2 - 6 hours depending on load)
- Uniform heating
- Fully insulated
- Audible and visual over-temp alarm
- UL/CUL approved
- FDA registered
- OSHPD pre-approved

Options

- Full view glass door
- Mobile dolly or cart
- 18" depth
- Full recess
- Pass through chamber
- Left hand door hinge
- Keyed door lock
- Temperature recorder
- Seismic brackets
- 220/240 V, 50/60HZ
- Custom sizes



(Model TWC24-G-TL-MB shown above on optional dolly)

Model # TWC24

Overall Size
30"W x 26.5"D x 78.25"T
14.00 cubic feet of storage
1 adjustable shelf

Upper Chamber I.D.
26"W x 23"D x 11.25"T
3.9 cubic feet of storage
Temperature range: 90-110 F.
Accuracy +/- 1 degree F. of set point

Intermediate Chamber
26"W x 23"D x 10.75"T
3.7 cubic feet of storage
Temperature range: 90-135 F.
Accuracy +/- 1 degree F. of set point

Lower Chamber I.D.
26"W x 23"D x 18.50"T
6.4 cubic feet of storage
Temperature range: 90-160 F.
Accuracy +/- 1 degree F. of set point

Electrical
120V, 13.5 amp., 50/60HZ
.65 kw/hr, 2238 btu/hr
UL/CUL listed
FDA registered



(Model DWC24-TL-MB shown above on optional dolly)

Model # DWC24

Overall Size
30"W x 26.5"D x 74.5"T
17.2 cubic feet of storage
3 adjustable shelves

Upper Chamber I.D.
26"W x 23"D x 15.25"T
5.27 cubic feet of storage
Temperature range: 90-160 F.
Accuracy +/- 1 degree F. of set point

Lower Chamber I.D.
26"W x 23"D x 34.5"T
11.93 cubic feet of storage
Temperature range: 90-160 F.
Accuracy +/- 3 degree F. of set point

Electrical
120V, 12 amp., 50/60HZ
.75 kw/hr, 2557 btu/hr
UL/CUL listed
FDA registered



(Model DWC2424-TL-MB shown above on optional dolly)

Model # DWC2424

Overall Size

24"W x 26.5"D x 74.5"T
15.95 cubic feet of storage
3 adjustable shelves

Upper Chamber I.D.

20"W x 23"D x 15.25"T
4.05 cubic feet of storage
Temperature range: 90-160 F.
Accuracy +/- 1 degree F. of set point

Lower Chamber I.D.

26"W x 23"D x 34.5"T
11.9 cubic feet of storage
Temperature range: 90-160 F.
Accuracy +/- 3 degree F. of set point

Electrical

120V, 10 amp., 50/60HZ
.46 kw/hr, 1570 btu/hr
UL/CUL listed
FDA registered



(Model DWC2460-G-TL shown above)

Model # DWC2460

Overall Size

24"W x 20.5"D x 64.75"T
7.45 cubic feet of storage
3 adjustable shelves

Upper Chamber I.D.

20"W x 17"D x 13.5"T
2.65 cubic feet of storage
Temperature range: 90-160 F.
Accuracy +/- 1 degree F. of set point

Lower Chamber I.D.

20"W x 17"D x 24.5"T
4.80 cubic feet of storage
Temperature range: 90-160 F.
Accuracy +/- 2 degree F. of set point

Electrical

120V, 10 amp., 50/60HZ
.49 kw/hr, 1678 btu/hr
UL/CUL listed
FDA registered



(Model DWC36-G-TL-MB shown above on optional dolly)

Model # DWC36

Overall Size

30"W x 26.5"D x 74.5"T
17.59 cubic feet of storage
4 adjustable shelves

Upper Chamber I.D.

26"W x 23"D x 25"T
8.63 cubic feet of storage
Temperature range: 90-160 F.
Accuracy +/- 2 degree F. of set point

Lower Chamber I.D.

26"W x 23"D x 26"T
8.96 cubic feet of storage
Temperature range: 90-160 F.
Accuracy +/- 2 degree F. of set point

Electrical

120V, 12 amp., 50/60HZ
.69 kw/hr, 2356 btu/hr
UL/CUL listed
FDA registered



(Model DWC60-G-TL shown above)

Model # DWC60

Overall Size

30"W x 20.5"D x 64.75"T
9.73 cubic feet of storage
3 adjustable shelves

Upper Chamber I.D.

26"W x 17"D x 13.5"T
3.46 cubic feet of storage
Temperature range: 90-160 F.
Accuracy +/- 1 degree F. of set point

Lower Chamber I.D.

26"W x 17"D x 24.5"T
6.27 cubic feet of storage
Temperature range: 90-160 F.
Accuracy +/- 2 degree F. of set point

Electrical

120V, 10 amp., 50/60HZ
.49 kw/hr, 1678 btu/hr
UL/CUL listed
FDA registered



Model # SWC1518

Overall Size
18"W x 15.5"D x 22"T

Chamber I.D.
14"W x 13"D x 13"T
1.4 cubic feet of storage
Temperature range: 90-135 F.
Accuracy +/- 1 degree F. of set point

Electrical
120V, 3.5 amp., 50/60HZ
.39 kw/hr, 1332 btu/hr
UL/CUL listed
FDA registered

(Model SWC1518-G-TL shown above)



Model # SWC1824

Overall Size
24"W x 20.5"D x 24.5"T

Chamber I.D.
20"W x 17"D x 15.25"T
3.0 cubic feet of storage
Temperature range: 90-160 F.
Accuracy +/- 1 degree F. of set point

Electrical
120V, 3.5 amp., 50/60HZ
.45 kw/hr, 1537 btu/hr
UL/CUL listed
FDA registered

(Model SWC1824-G-TL shown above)



Model # SWC24

Overall Size
30"W x 26.5"D x 24.5"T
1 adjustable shelf

Chamber I.D.
26"W x 23"D x 15.25"T
5.27 cubic feet of storage
Temperature range: 90-160 F.
Accuracy +/- 1 degree F. of set point

Electrical
120V, 7.5 amp., 50/60HZ
.30 kw/hr, 1024 btu/hr
UL/CUL listed
FDA registered

(Model SWC24-G-TL shown above)



Model # SWC2460

Overall Size
24"W x 20.5"D x 64.75"T
3 adjustable shelves

Chamber I.D.
20"W x 17"D x 49.5"T
9.73 cubic feet of storage
Temperature range: 90-160 F.
Accuracy +/- 1 degree F. of set point

Electrical
120V, 7.5 amp., 50/60HZ
.49 kw/hr, 1678 btu/hr
UL/CUL listed
FDA registered

(Model SWC2460-G-TL-MB shown above on optional dolly)



Model # SWC36

Overall Size
30"W x 26.5"D x 36"T
2 adjustable shelves

Chamber I.D.
26"W x 23"D x 25"T
8.63 cubic feet of storage
Temperature range: 90-160 F.
Accuracy +/- 2 F. degree of set point

Electrical
120V, 7.5 amp., 50/60HZ
.35 kw/hr, 1195 btu/hr
UL/CUL listed
FDA registered

(Model SWC36-G-TL shown above)



Model # SWC60

Overall Size
30"W x 20.5"D x 64.5"T
3 adjustable shelves

Chamber I.D.
26"W x 17"D x 51"T
13.05 cubic feet of storage
Temperature range: 90-160 F.
Accuracy +/- 3 degree F. of set point

Electrical
120V, 7.5 amp., 50/60HZ
.46 kw/hr, 1570 btu/hr
UL/CUL listed
FDA registered

(Model SWC60-G-TL-MB shown above on optional dolly)



Model # SWC72

Overall Size
30"W x 26.5"D x 74.5"T
2 adjustable shelves
2 fixed shelves

Chamber I.D.
26"W x 23"D x 61"T
21 cubic feet of storage
Temperature range: 90-160 F.
Accuracy +/- 3 degree F. of set point

Electrical
120V, 7.5 amp., 50/60HZ
.53 kw/hr, 1810 btu/hr
UL/CUL listed
FDA registered

(Model SWC72-G-TL-MB shown above on optional dolly)

Optional Mobile Stands:



Half size and counter top units
(If ordered with warmer add -MS to the model #)

T0007: 26"W x 34"D x 34"T
Recommended for models SWC24 and SWC36

T0023: 26"W x 20"D x 34"T
Recommended for models SWC1518 and SWC1824

Optional Mobile Base:



Newly Redesigned Mobile Base:

T0087: 33"W x 28"D x 6.75"T
(If ordered with the warmer, add -MB to the model #.
Note this will add 2" to the standard warmer height)



Standard keyed temperature lockout



Optional door lock

How to order Blanket & Fluid Warming Cabinets

Options Available	18" Depth	Glass Doors	Mobile Base	Mobile Stand	Recessed Unit	LH Door Swing, Hinges on Left	Keyed Door Lock	Temperature Recorder	220/240 V, 50/60 HZ	Pass Through Chamber
Option Extension	18	G	MB	MS	R	LH	DL	TR	220	P

For Example: Model # DWC24 with the 18" depth option, Glass Doors, Recessed unit, Hinges on the left, Keyed door lock, 220/240 V 50/60 HZ = Order Model # DWC24-18-G-R-LH-DL-220

If you require any assistance please call us with any questions at (618) 476-3550 or toll free at 1-877-828-9975.

Standard Models

Model #	Outside Dimensions
Triple Chamber Units	
TWC24	30"W x 26.5"D x 78.25"T
TWC24-G	30"W x 26.5"D x 78.25"T
Double Chamber Units	
DWC24	30"W x 26.5"D x 74.5"T
DWC24-G	30"W x 26.5"D x 74.5"T
DWC2424	24"W x 26.5"D x 74.5"T
DWC2424-G	24"W x 26.5"D x 74.5"T
DWC2460	24"W x 20.5"D x 64.75"T
DWC2460-G	24"W x 20.5"D x 64.75"T
DWC36	30"W x 26.5"D x 74.5"T
DWC36-G	30"W x 26.5"D x 74.5"T
DWC60	30"W x 20.5"D x 64.75"T
DWC60-G	30"W x 20.5"D x 64.75"T
Single Chamber Units	
SWC1518	18"W x 15.5"D x 22"T
SWC1518-G	18"W x 15.5"D x 22"T
SWC1824	24"W x 20.5"D x 24.5"T
SWC1824-G	24"W x 20.5"D x 24.5"T
SWC24	30"W x 26.5"D x 24.5"T
SWC24-G	30"W x 26.5"D x 24.5"T
SWC2460	24"W x 20.5"D x 64.75"T
SWC2460-G	24"W x 20.5"D x 64.75"T
SWC36	30"W x 26.5"D x 36"T
SWC36-G	30"W x 26.5"D x 36"T
SWC60	30"W x 20.5"D x 64.75"T
SWC60-G	30"W x 20.5"D x 64.75"T
SWC72	30"W x 26.5"D x 74.5"T
SWC72-G	30"W x 26.5"D x 74.5"T

NOTE: Due to the vast number of sizes we have available, not all of our models are shown. Please let us know your specific dimensions to get the model that will best suit your needs. **If we don't currently have the size you need, we will build a custom one for you!**

WARRANTY

All warming cabinets manufactured by MAC Medical, Inc. will carry a lifetime guarantee against product craftsmanship, 1-year labor and 2-year parts guarantee. The factory will service all units without cost to the buyer for 1-year from shipment. After the 1-year period, replacement of a defective part (labor) will be at buyer's expense. We will exchange all defective parts at no cost to the buyer for a period of 2-years from shipment. All defective parts must be returned within 30 days to ensure proper credit. An RMA from MAC Medical, Inc. must be obtained prior to items return.

SURGICAL SCRUB SINKS

SS SERIES SURGICAL SCRUB SINKS

Manufactured of the highest quality possible, Mac Medical delivers a full line of hands free, fully functional Surgical Scrub Sinks. Combining the best materials, components, and craftsmanship available, each sink is hand built to the customer's specific need.

SS Series Scrub Sink Standard Features:

- Deep sloping basin
- Adjustable thermostatic controlled pressure regulating mixing valve, one per station
- Check stop strainers for ease of maintenance
- High mount swivel gooseneck spout with adjustable swivel spray aerator
- Flow control valve
- Backflow preventers
- Infrared sinks are equipped with a 24 volt plug in transformer
- Splash screen dividers with double and triple station sinks
- Main support and Z-brackets (in-wall support optional)
- 304 stainless steel polished and ground to a #4 finish

Knee Operated Surgical Scrub Sinks:

The operation of these sinks is simple. Press the knee panel one time to activate water flow. Press again to stop flow. The soap panel works in a pumping fashion with soap being dispensed through a stainless steel spout located near the mixing valve. The base has been designed to accommodate gallon sized soap container storage behind the knee panels.

Infrared Operated Surgical Scrub Sinks:

The infrared sensor is located on the front of each station and is activated by the user's waist. There is a 2 second on/off delay for water flow. The sensor range is 12" to 14". Both features combined eliminate activation by simply passing by. Optional knee operated or foot control soap pumps are available.

Deluxe Surgical Scrub Sinks:

Built as a hybrid, these sinks have dual controls. Equipped with infrared operated water control as well as a manual bypass for knee operated water control. The main operation is via the infrared sensor located between the knee panels. The knee operation for water control is on standby as a backup. In addition the sink is also equipped with knee operated soap.



Knee Operated Surgical Scrub Sink
Model # SS32-PB
Pedestal Base Shown



Infrared Operated Surgical Scrub Sink
Model # SS32-IR-FSP



Deluxe Surgical Scrub Sink
Model # SS64-IR-MB

SS Series Surgical Scrub Sinks Features and Options:



Model # SS96-IR-MB-TM-EYE

Optional Recommended Products:

Sink Model	In-Wall Chair Carrier #	Shelf Over Sink #	Lighted Shelf Over Sink #
SS32	S0001	SH0001	LSH0001
SS64	S0002	SH0002	LSH0002
SS96	S0003	SH0003	LSH0003

How To Order SS Series Sinks:

Options Available	Infrared Operation	Manual Bypass to add Knee Operated Water and Soap With IR Operation	Knee Operated Soap With IR Operation	Foot Operated Soap (All Sinks)	Digital Scrub Timer	Eye Wash	220-240V	Pedestal Base
Option Extension	IR	MB	KSP	FSP	TM	EYE	220	PB

Single Station Scrub Sink: Model SS32 - _____ - _____ - _____ - _____ - _____ - _____ - _____ - _____ - _____
 Dual Station Scrub Sink: Model SS64 - _____ - _____ - _____ - _____ - _____ - _____ - _____ - _____ - _____
 Triple Station Scrub Sink: Model SS96 - _____ - _____ - _____ - _____ - _____ - _____ - _____ - _____ - _____

Example: Model # SS64 Infrared Operated with Knee Operated Water and Soap plus Digital Scrub Timers = Our Model # SS64-IR-MB-TM.



1/2" WATER SUPPLY LINE DETAIL
USED ON ALL SS SERIES SINKS

SS Series Surgical Scrub Sinks Specs:

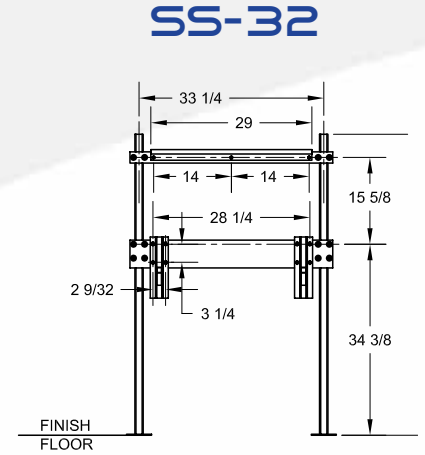
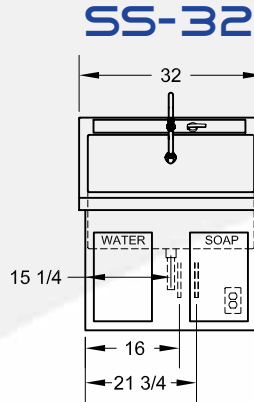
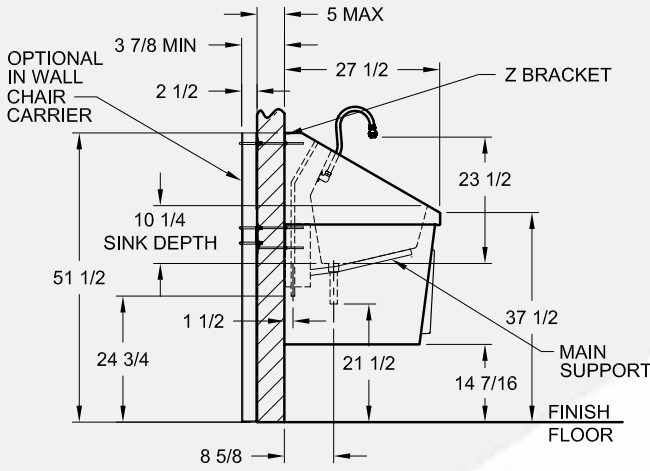

SS-64

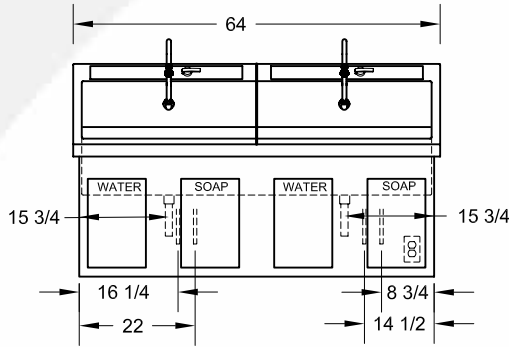

SS-64

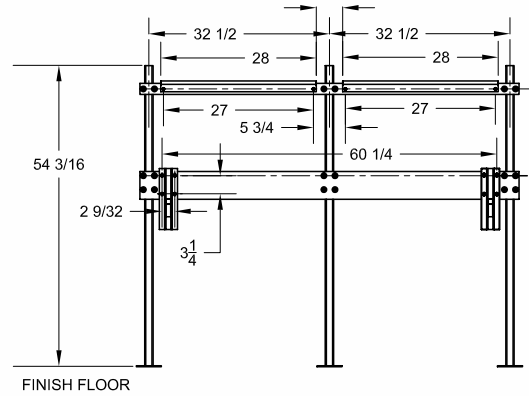

SS-96

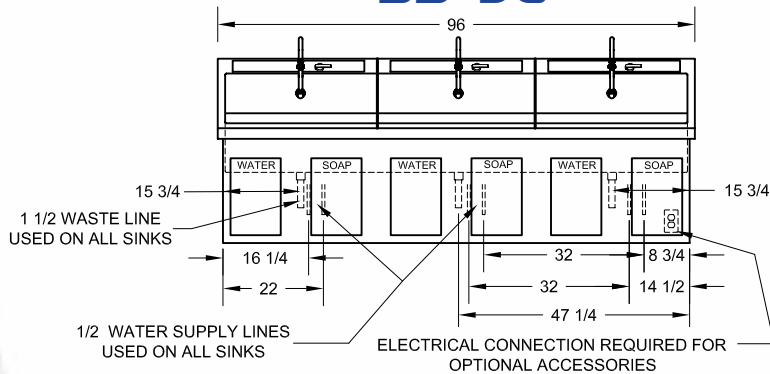

SS-96

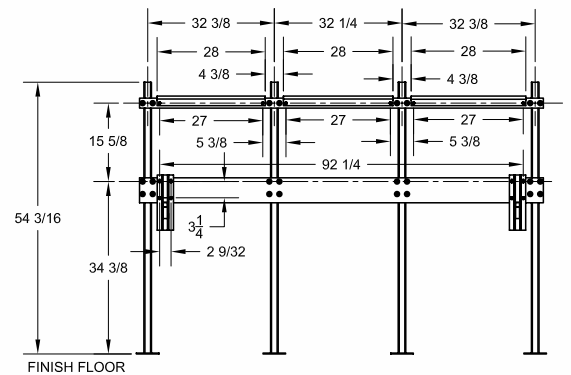

ES SERIES SURGICAL SCRUB SINKS

Our ES series scrub sinks were developed to be the answer to space and economical constraints. The ES series sinks have a smaller outside dimension but still have a deep basin to allow for a proper scrub. The operation of the ES sinks are the same as that of the SS series sinks but the features do vary.

ES Series Scrub Sink Standard Features:

- Deep sloping basin
- Adjustable thermostatic controlled pressure regulating mixing valve, one per station mounted under sink
- High mount swivel gooseneck spout with adjustable swivel spray aerator
- Flow control valve
- Backflow preventers
- Infrared sinks are equipped with a 24 volt plug in transformer
- Z-brackets (See specifications on rear panel for in-wall support)
- 304 stainless steel polished and ground to a #4 finish



Single Station Scrub Sink
Model # ES25-IR-MB



Dual Station Scrub Sink
Model # ES47-IR

How To Order ES Series Sinks:

Options Available	Infrared Operation	Manual Bypass to add Knee Operated Water and Soap With IR Operation	Knee Operated Soap (Soap Is Not A Standard Feature With Knee Operated Water on ES series sinks)	Foot Operated Soap (All Sinks)	Digital Scrub Timer	Eye Wash	220-240V	Pedestal Base
Option Extension	IR	MB	KSP	FSP	TM	EYE	220	PB

Single Station Scrub Sink: Model # ES25 - ____ - ____ - ____ - ____ - ____ - ____ - ____ - ____

Dual Station Scrub Sink: Model # ES47 - ____ - ____ - ____ - ____ - ____ - ____ - ____ - ____

Example: Model # ES47 with infrared operated and knee operated soap and water plus digital scrub timer = model # ES47-IR-MB-TM.

ES Series Surgical Scrub Sinks Specs:

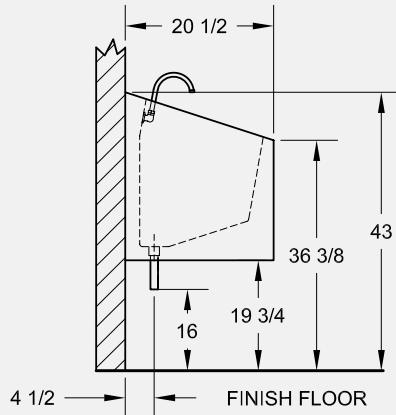

ES-25

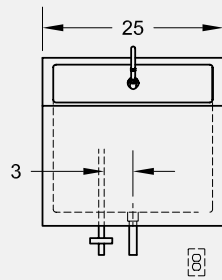

ES-25

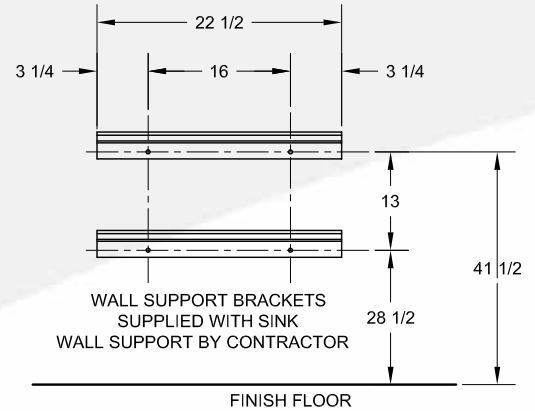

ES-47

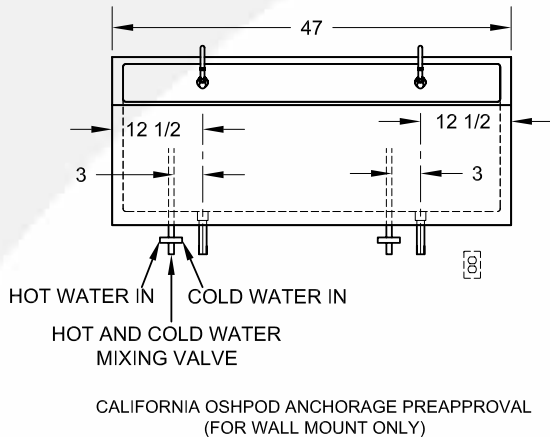

ES-47

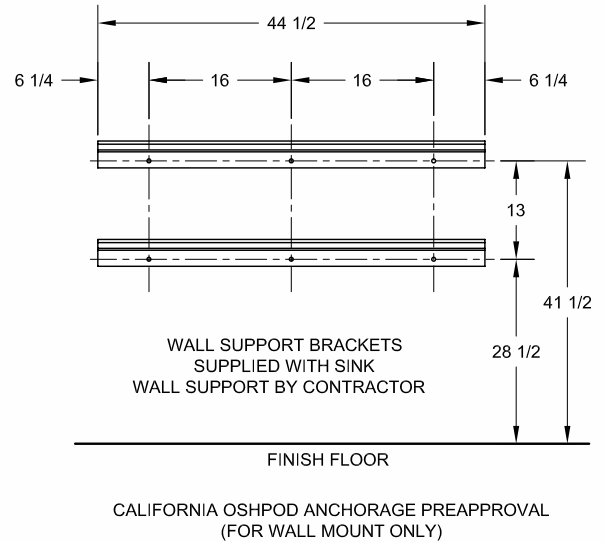

Surgical Scrub Sink Utility Requirements:

Utility	Connection On Unit	Pressure Range	Temperature	Consumption
Drain	1 1/2" x 6" Tail Piece	N/A	N/A	N/A
Cold Water	1/2" NPT	20-50 PSIG	70 Degree F. Max	2 GPM Per Station
Hot Water	1/2" NPT	20-50 PSIG	180 Degree F. Max	2 GPM Per Station
Electrical (IR Units Only)	120V	N/A	N/A	N/A

WARRANTY

All Surgical Scrub Sinks manufactured by MAC Medical, Inc. will carry a limited lifetime warranty against manufacturing defects and a one year parts and labor warranty. The factory will service all units without cost to the buyer for one year from shipment. After the one year period, replacement of a defective part will be at buyer's expense. We will exchange all defective parts at no cost to the buyer for a period of one year from shipment. All defective parts must be returned within 30 days to ensure proper credit. An RMA from MAC Medical, Inc. must be obtained prior to items return.



TRANSPORT & EYE STRETCHERS

MODEL # PT-1000



Standard Features:

- 8" Tente total/directional locking casters
- Brake steer pedals all 4 corners
- Single cylinder Fowler assist
- Dual pedestal lift mechanism
- Trendelenburg/reverse Trendelenburg
- Lift/Trendelenburg pedals on both sides
- Fold forward side rails with built in push handles
- 4" standard mattress
- 2 hook removable telescopic I.V. pole
- I.V. pole sockets at all corners
- O2 storage underneath

Optional Features:

- Fold down push handles
- Manual knee gatch
- Manual Fowler
- 29" or 31" wide patient surface

Product Specifications:

Dimensions:

- Overall: 83" long x 31" wide
- Patient surface: 75" long x 26" wide

PT1000-29 Wide:

- Overall: 83" long x 34" wide
- Patient surface: 75" long x 29" wide

PT1000-31 Extra Wide:

- Overall: 83" long x 36" wide
- Patient surface: 75" long x 31" wide
- Equipped with dual fowler assist

Height Adjustment Range:

- Minimum 23" • Maximum 35"

Litter Positioning:

- Trend/reverse trend: +/- 18 degrees
- Fowler position: 90 degrees
- I.V. attachment sockets: 4
- Weight capacity: 550 pounds

TRANSPORT & EYE STRETCHERS

MODEL # PT2000-EYE



Newly redesigned low profile dual articulating head attachment



Standard Features:

- “NEW” quick adjustment dual articulating head attachment
 - Low profile for surgeons leg room
 - 8” Tente total/directional locking casters
 - Brake steer pedals all 4 corners
 - Manual Fowler assist
 - Manual knee gatch
 - Dual pedestal lift mechanism
 - Trendelenburg/reverse Trendelenburg
 - Lift/Trendelenburg pedals on both sides
 - Fold forward side rails with built in push handles
 - 4” standard mattress
 - 2 hook removable telescopic I.V. pole
 - I.V. pole sockets at all corners
 - O2 storage underneath
- (Optional wrist rest available)

Product Specifications:

Dimensions:

- Overall: 94” long x 31” wide
- Patient surface: 85” long x 25” wide

PT2000-29-EYE Wide:

- Overall: 94” long x 35” wide
- Patient surface: 85” long x 29” wide

PT2000-31-EYE Extra Wide:

- Overall: 94” long x 37” wide
- Patient surface: 85” long x 31” wide

Height Adjustment Range:

- Minimum 23” • Maximum 35”

Litter Positioning:

- Trend/reverse trend: +/- 18 degrees
- Fowler position: 90 degrees
- I.V. attachment sockets: 4
- Weight capacity: 550 pounds

TABLES

INSTRUMENT & BACK TABLES



Standard Features:

- Fully-welded construction
- Reinforced tops
- Durable 1 1/4" 16 gauge stainless steel legs
- 16 gauge type 304 stainless steel top
- 18 gauge type 304 stainless steel under shelf
- 2" swivel casters

Options:

- 3" Swivel casters
- Locking casters
- Drawers under all sizes
- Stainless steel guard rails
- H or U brace instead of under shelf
- Nesting sets
- Multiple under shelves

*Additional sizes available for specific requirements.
Please contact us for further assistance.*

Model #	Width	Depth	Height
T0001	16	20	34
T0002	16	30	34
T0003	24	36	34
T0004	24	48	34
T0005	24	60	34
T0006	24	72	34

PREP STANDS / UTILITY TABLES

Available in 3 models: single, double and triple drawers. Size: 16"D x 20"W x 34"H.

Additional sizes available for specific requirements.



Single Drawer - T0086



Double Drawer - T0077



Triple Drawer - T0096

STERILE PROCESS & WORK TABLES

Standard Features:

- Fully-welded construction
- Sound-proofed reinforced tops
- Durable 1 1/4" to 1 5/8" 16 gauge type 304 stainless steel legs
- 16 gauge type 304 stainless steel top
- 18 gauge type 304 stainless steel under shelf
- 5" swivel casters or adjustable legs

All tables are manufactured to individual specifications

Options:

- Hydraulic adjustable heights for ergonomics
- 5" swivel casters
- Locking casters
- Full base unit underneath
- Drawers under all sizes
- Stainless steel guard rails
- H or U brace instead of under shelf
- Nesting sets
- Multiple under shelves

Sample Tables:

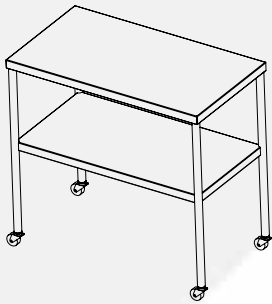

TABLE WITH UNDER SHELF

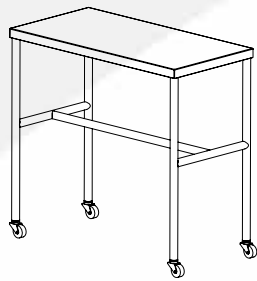

TABLE WITH "H" BRACE

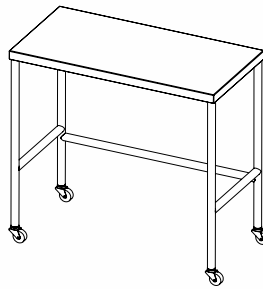
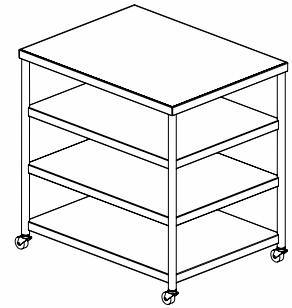
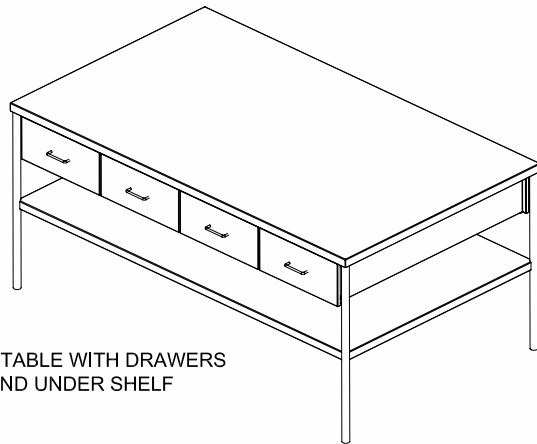

TABLE WITH "U" BRACE



MULTIPLE UNDER SHELVES



WORK TABLE WITH DRAWERS AND UNDER SHELF

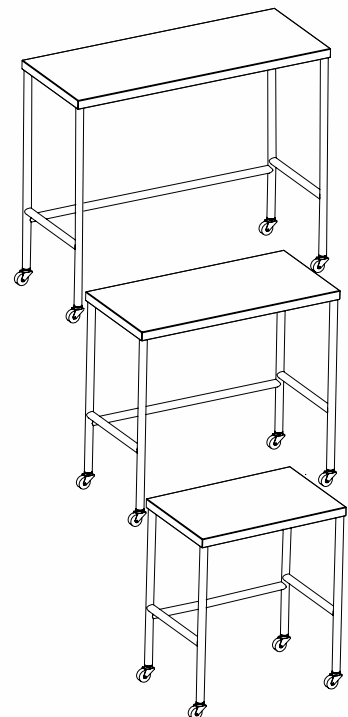

NESTING TABLES

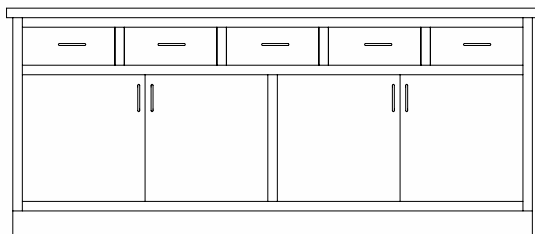

WORK TABLE WITH DRAWERS AND DOORS ON BOTH SIDES

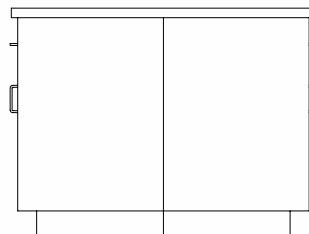

CASE CARTS

Mac Medical, Inc. manufactures a full line of sterile pack transport case carts. As with all of our products, case carts are built with quality and durability in mind.



Standard Features

- Fully-welded construction
- Sound-proofed tops and doors for quiet operation
- 8.5" x 11" card holder
- Adjustable perforated stainless steel roll out shelves
- Exterior push handles for better control and more interior space
- Non marring wrap-around bumper
- Positive lock door latches
- Sealed doors for sterility control
- Large 6" diameter, easy rolling, cart-washable casters with sealed bearings

Options

- Fully extended perforated roll out shelves
- Top extension shelves
- Stainless steel casters
- Directional locks
- Total locks
- Silicon door gasket for complete sterility control
- Door safety seal tab to ensure door close through transport

All carts can be manufactured to individual specifications

Model	Case Dimension			OA Dimension			Adjustable Shelves	Card Holder
	Width	Depth	Height	Width	Depth	Height		
MMCC1	26	24.25	47.25	31.75	28.375	56.375	2	1
MMCC2	28.5	28.5	47.25	34.25	32.625	56.375	2	1
MMCC3	40.25	24.25	30.25	46	28.375	39.375	1	1
MMCC4	40.25	24.25	47.25	46	28.375	56.375	2	1
MMCC5	36	25	47.25	41.75	29.125	56.375	2	1
MMCC6	23.625	25	30.5	29.375	29.125	39.625	1	1
MMCC7	35.5	24	44.5	41.25	28.125	53.625	2	1
MMCC8	23	24.25	28.5	28.75	28.375	37.625	1	1
MMCC9	23.625	25	46.25	29.375	29.125	55.375	2	1
MMCC12	36	25	31	41.75	29.125	40	1	1
MMCC14	46.5	25.25	31.25	52.25	29.375	40.25	2	1

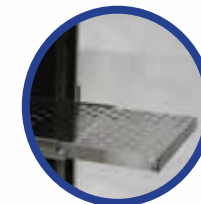
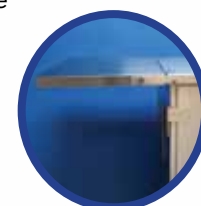

OPEN CASE CARTS



Model # MMOCC13

- Overall size: 40.375"W x 28.625"D x 41.125" H
- Case dimensions: 36"W x 25"D x 30.125"H
- Open design
- Full wrap around non-marring bumper
- 1 Stainless steel adjustable shelf with fixed stainless steel top and bottom
- Stainless steel guard rail

Options:

- Wire grid on back side
- 8" casters
- Wire shelves
- Push handles
- Custom sizes

with optional
push handles

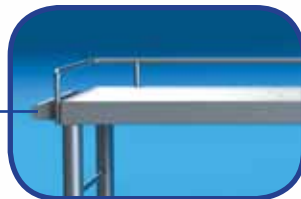

(Shown with optional wire shelves)

Model # MMOCC16

- Overall size: 60.375"W x 26.125"D x 67"H
- Heavily built distribution cart, perfect for storage, supplies, linen or distribution
- Full wrap around non-marring bumper
- Standard with 3 solid stainless steel adjustable shelves

Options:

- Wire grid on back side
- 8" casters
- Wire shelves
- Custom sizes

PROCESSING SINKS



Standard Features:

- Fully-welded construction
- Sound-proofed reinforced tops
- Multiple layouts for individual requirements
- All sinks are manufactured to individual specifications
- Full CAD rendering of specified sink

Options:

- Hydraulic adjustable heights for ergonomics
- Full base unit underneath with any door, drawer or open shelf combination
- Pipe stand instead of base unit
- Multiple bowls in any combination
- Multiple faucet options including pre-rinse
- Air hose with 5 blowgun tips
- DI water
- Foot operated drains

Sample Processing Sinks:

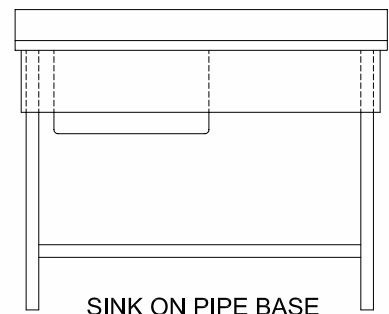
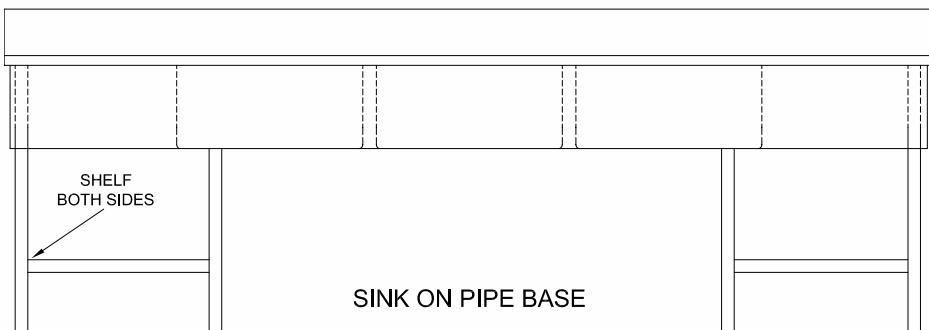
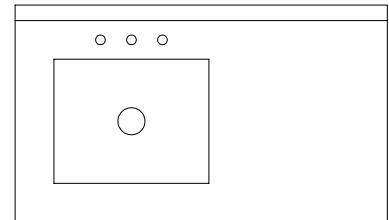
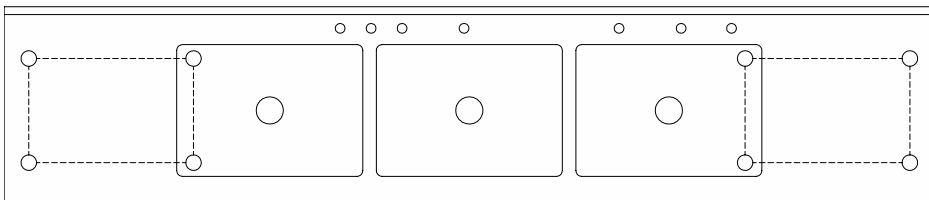

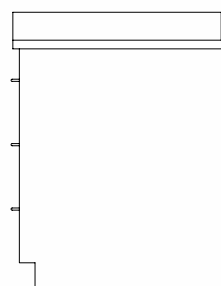
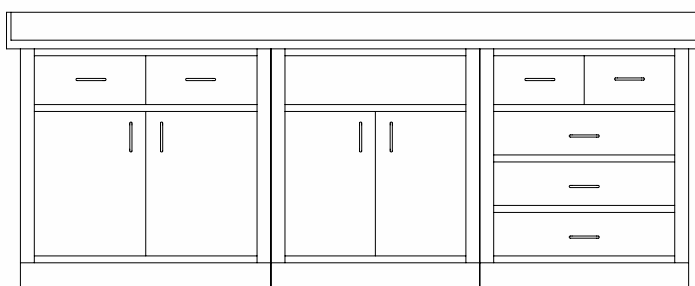
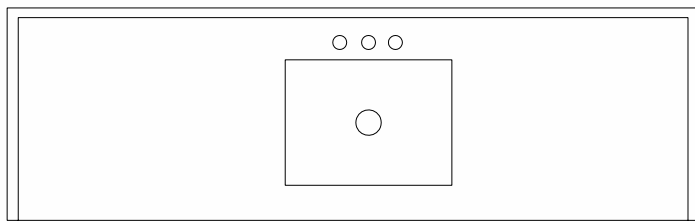
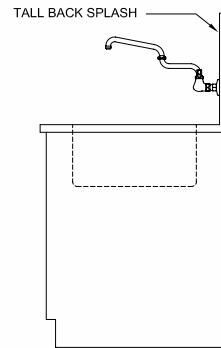
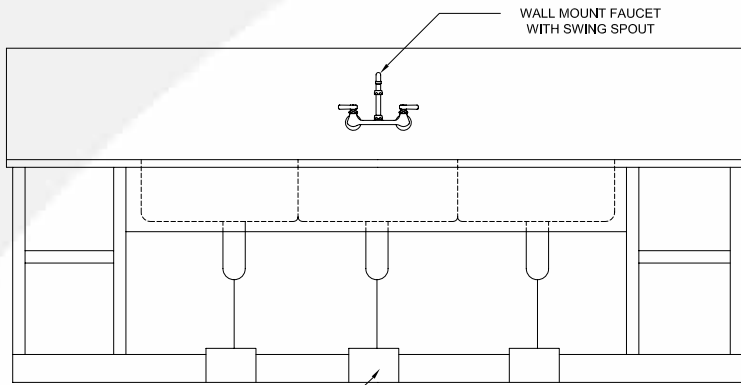
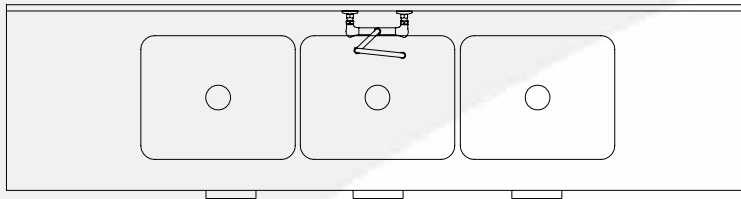
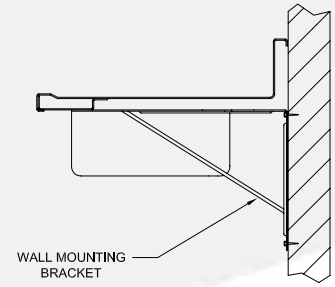
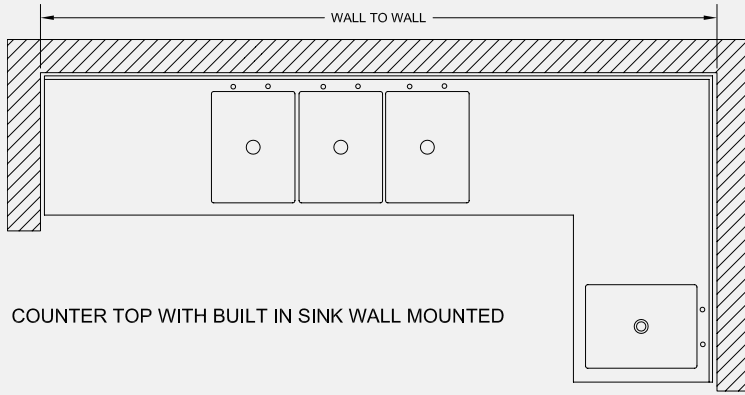

SINK ON CABINET BASE WITH DRAWERS AND DOORS

STAINLESS STEEL CABINETRY



Supply Storage Cabinets

Overheads

Nurse Doc. Station

Supply Storage Cabinets

Standard Features:

- Fully-welded construction
- Multiple layouts for individual requirements
- Full CAD renderings
- Engineered room layouts in CAD

Options:

- Glass or stainless steel hinged doors
- Glass or stainless steel sliding doors
- Freestanding, recess or on mobile casters
- T-Handle locks
- Pegboard back
- Drawers
- Variable height bases
- Slope tops
- Electronic keypad door locks
- Pull out catheter hooks with card holder
- Pass through construction

Standard Sizes:

- Depths: 18" and 24"
- Widths: 24", 30", 36", 48" and 60"
- Flat top heights: 60", 64", 72", 78" and 84"
- Slope top heights: 70", 78", 84" and 90"

Any size can be manufactured per required specifications.

Nurses Documentation Stations

Standard Features:

- Fully-welded construction
- Recess or free standing
- Multiple layouts for individual requirements
- Heavy duty pull out drawers
- Vented closures for electronics
- Integrated wire management system
- Open backs for easy install
- Pull out shelf for easy PC install
- Base units, wall units and overhead units available
- Full CAD renderings
- Engineered room layouts in CAD

Options:

- Glass or stainless steel doors
- Pull out writing surface
- Overhead lighting
- Magnetic back board
- Pegboard panels
- Recess or freestanding
- T-Handle locks
- Variable height bases
- Electronics keypad door locks

Overhead Storage Cabinets

Standard Features:

- Fully-welded construction
- Multiple layouts for individual requirements
- Full CAD renderings
- Engineered room layouts in CAD

Options:

- Glass or stainless steel hinged doors
- Sliding glass doors
- T-Handle locks
- Pegboard back
- Drawers
- Slope tops
- Electronic keypad door locks
- Pass through construction

SUPPLY STORAGE CABINETS:

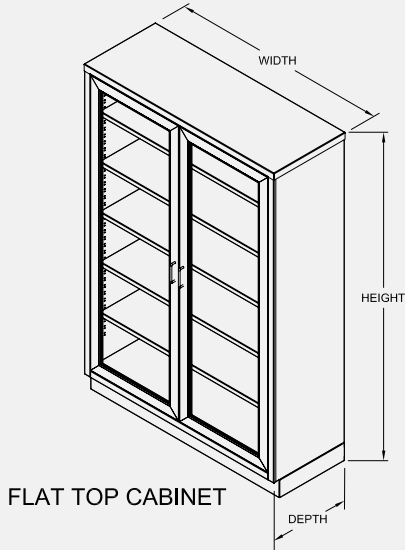

FLAT TOP CABINET

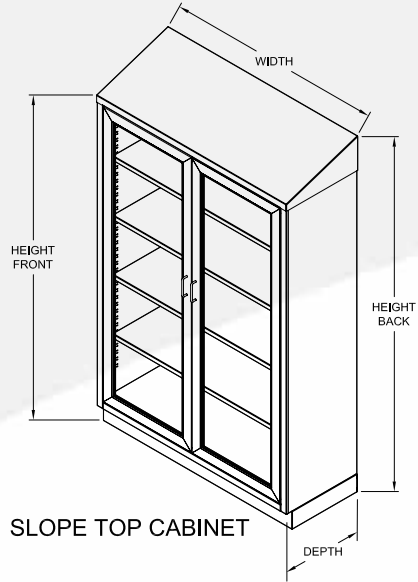

SLOPE TOP CABINET

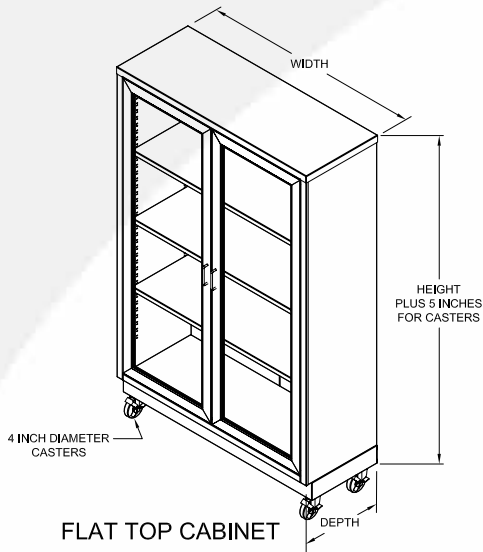

FLAT TOP CABINET

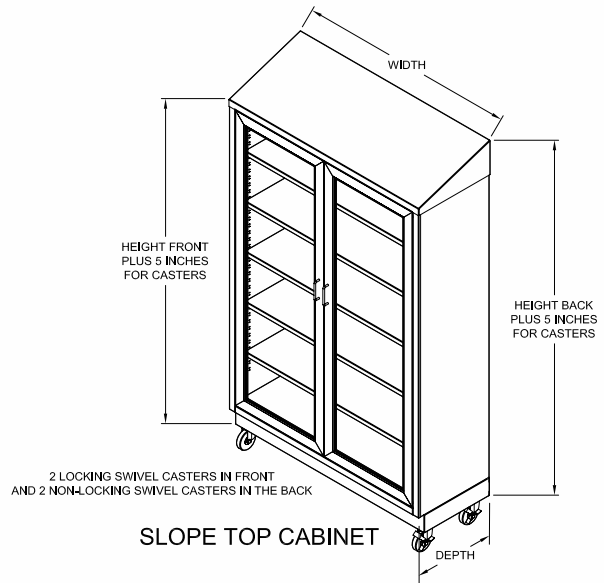

SLOPE TOP CABINET

STORAGE CABINET

STORAGE CABINET

WARMING CABINET

DESK CABINET

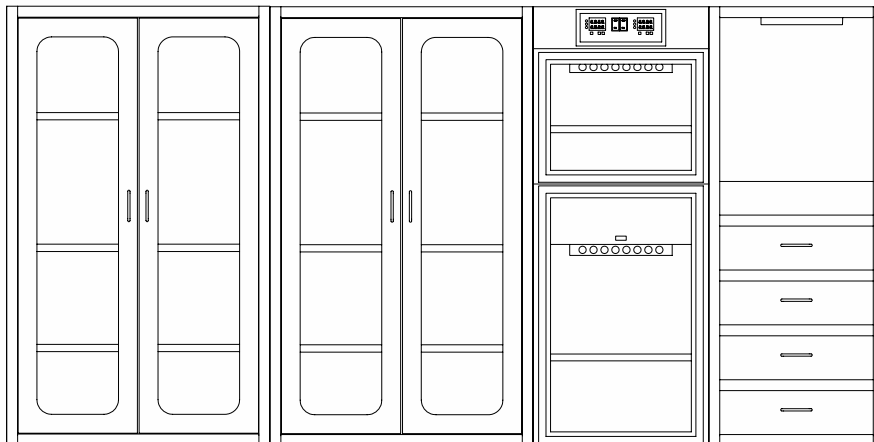

ANY COMBINATION OF STORAGE CABINETS, DESK CABINETS, AND WARMING CABINETS CAN CREATE A CONTINUOUS BANK OF CABINETS.

NURSES DOCUMENTATION STATION

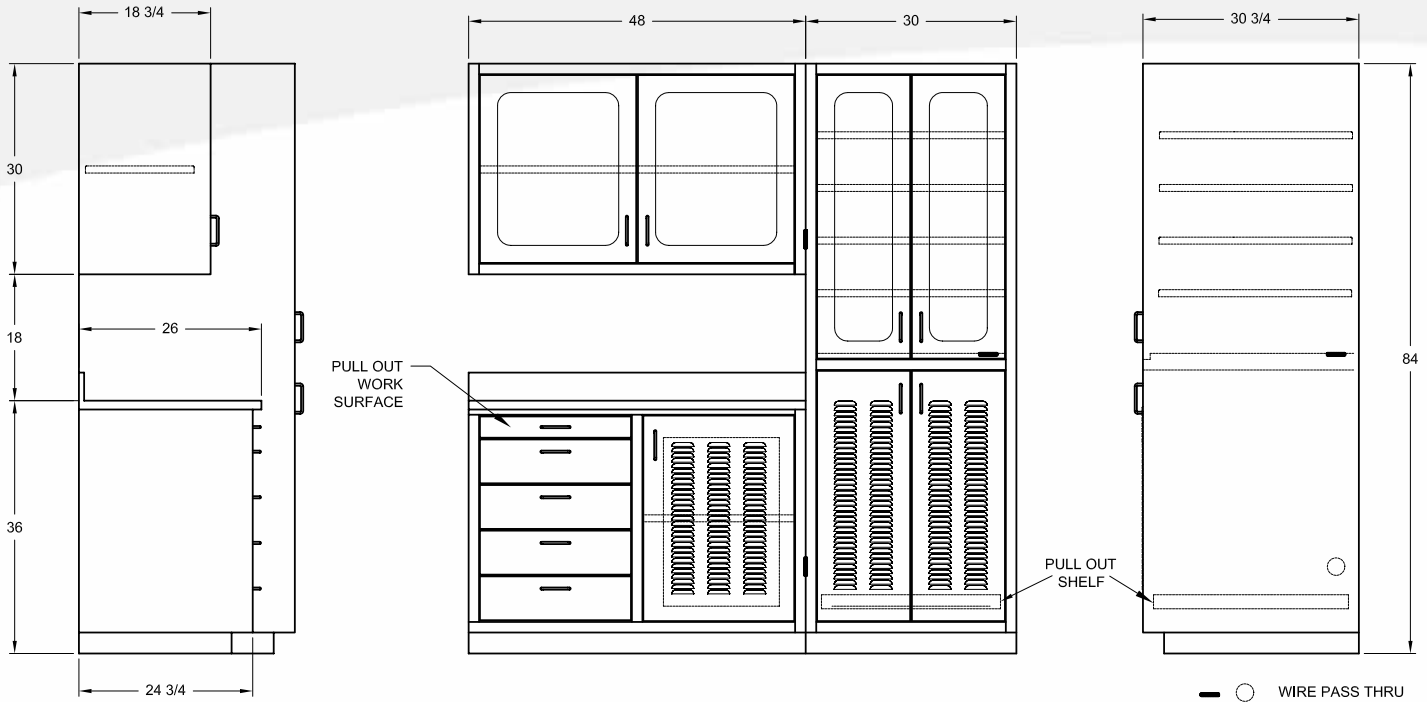

DOCUMENTATION SHOWN WITH TOWER ON THE RIGHT SIDE.
DOCUMENTATION STATION CAN BE CONFIGURED WITH THE TOWER ON THE LEFT SIDE.

WE CAN CUSTOMIZE ANY COMPONENT OF THIS DOCUMENT STATION
TO FIT A SPECIFIC SPACE OR USER REQUIREMENT.

STORAGE CABINET

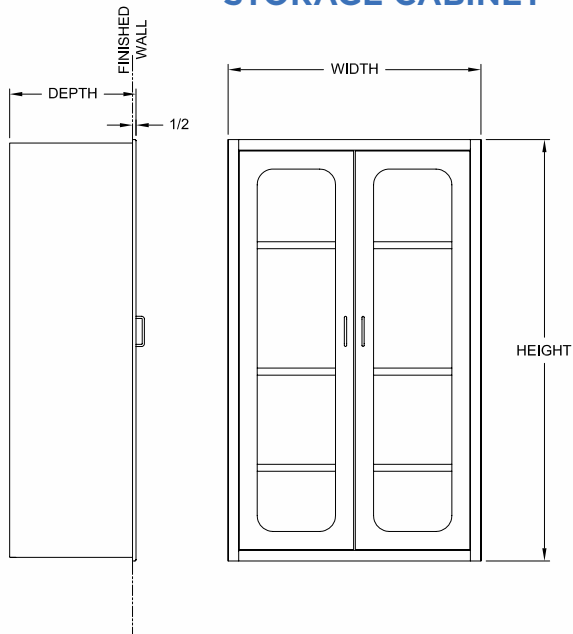

STANDARD SIZES
DEPTH 16", 18", 24"
WIDTHS 24", 30", 36", 48", 60"
HEIGHTS 60", 72"

ANY SIZE CAN BE MANUFACTURED PER REQUIRED SPECIFICATION

DESK CABINET

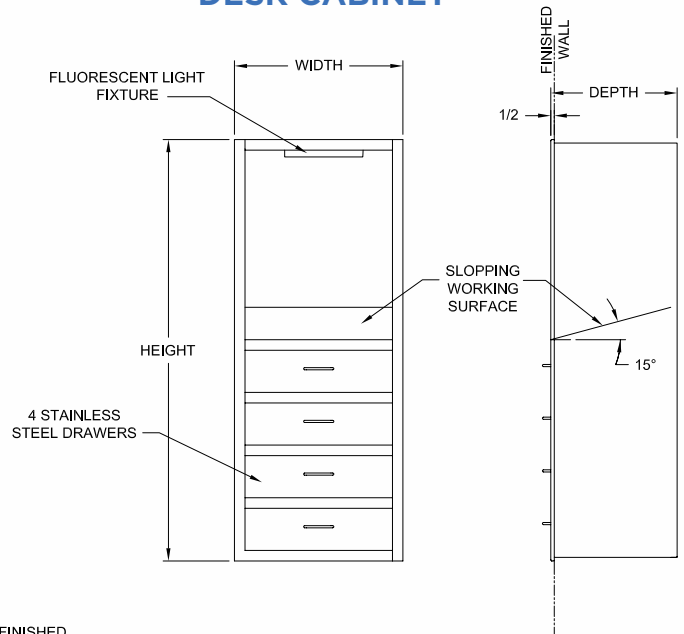

STANDARD SIZES
DEPTH 16", 18", 24"
WIDTHS 24", 30", 36"
HEIGHTS 60", 72"

ANY SIZE CAN BE MANUFACTURED PER REQUIRED SPECIFICATION

MAYO STANDS



MYO-2000

MYO-2000

- Fully-welded stainless steel construction
- Removable 21 1/4" x 16 1/4" stainless steel tray
- Foot operated friction lock height adjustment / dual post
- 2" casters

MYO-2001

- Same as MYO-2000 except 19 1/8" x 12 5/8" stainless steel tray

MYO-2002

- Same as MYO-2000 except 25" x 20" stainless steel tray



MYO-3000

MYO-3000

- Fully-welded stainless steel construction
- Removable 21 1/4" x 16 1/4" stainless steel tray
- Hand operated friction lock height adjustment / dual post
- 2" casters

MYO-3001

- Same as MYO-3000 except 19 1/8" x 12 5/8" stainless steel tray

MYO-3002

- Same as MYO-3000 except 25" x 20" stainless steel tray



MYO-4000

MYO-4000

- Fully-welded stainless steel construction
- Removable 21 1/4" x 16 1/4" stainless steel tray
- Manual knob operated adjustment / single post
- 2" casters

MYO-4001

- Same as MYO-4000 except 19 1/8" x 12 5/8" stainless steel tray



MYO-5000

MYO-5000

- Fully-welded stainless steel construction
- Removable 21 1/4" x 16 1/4" stainless steel tray
- Foot operated friction lock height adjustment / single post
- 2" casters

MYO-5001

- Same as MYO-5000 except 19 1/8" x 12 5/8" stainless steel tray



MYO-6000

MYO-6000

- Fully-welded stainless steel construction
- Removable 21 1/4" x 16 1/4" stainless steel tray
- Thumb operated friction lock height adjustment / single post
- 2" casters

MYO-6001

- Same as MYO-6000 except 19 1/8" x 12 5/8" stainless steel tray

OPTION: (-MB) MOBILE BASE



RING STANDS

- Available in single and double basin designs
- Fully welded stainless steel construction
- Available with lower shelf
- 2" casters cap swivel
- Accessible from any side with open frame design



SOL-1000

- Overall size: 14"D x 14"W x 34"H
- Removable 7 quart stainless steel basin

SOL-1000-8.5

- Optional 8 1/2 quart basin



SOL-1001

- Same as SOL-1000 except with stainless steel lower shelf

SOL-1001-8.5

- Optional 8 1/2 quart basin



SOL-2000

- Overall size: 14"D x 28"W x 34"H
- Two removable 7 quart stainless steel basins

SOL-2000-8.5

- Optional 8 1/2 quart basins



SOL-2001

- Same as SOL-2000 except with stainless steel shelf

SOL-2001-8.5

- Optional 8 1/2 quart basins

IV STANDS

- Fully welded stainless steel construction
- 2" swivel casters
- Tip resistant base
- 68" - 108" height adjustment



IVS-1000 Series

- Hand operated
- 5-Leg stand

IVS-1002

- Two-hook design

IVS-1004

- Four-hook design

IVS-1006

- Six-hook design

IVS-2000 Series

- Hand operated
- 4-leg stand

IVS-2002

- Two-hook design

IVS-2004

- Four-hook design

IVS-2006

- Six-hook design



IVS-3000 Series

- Foot operated
- 5-Leg stand

IVS-3002

- Two-hook design

IVS-3004

- Four-hook design

IVS-3006

- Six-hook design

IVS-4000 Series

- Foot operated
- 4-Leg stand

IVS-4002

- Two-hook design

IVS-4004

- Four-hook design

IVS-4006

- Six-hook design

KICK BUCKETS

- Stainless steel frame
- Perimeter bumper to protect walls
- 2" swivel casters
- Tip resistant



KB-1000



KB-2000

KB-1000

- Overall size: 14"H x 13 1/2" diameter
- Removable 12 quart stainless steel basin

KB-2000

- Overall size: 8"H x 16 1/4" diameter
- Removable 8 1/2 quart stainless steel basin

LINEN HAMPERS

- Fully-welded, heavy gauge all stainless steel construction
- 3" double ball bearing, swivel casters
- Full, heavy gauge stainless steel platform to support bags & ease of removal

Available options:

- FOL = Foot operated stainless steel lid
- BG = Rotating bumper guards over casters
- Capitalize foot and rotating

1000 Series



LH-1000

- Overall size: 35"H x 57 1/4" perimeter
- Accommodates 18" diameter bags

2000 Series



LH-2000

- Overall size: 35"H x 18" diameter
- Accommodates 18" diameter bags



LH-1001

- Overall size: 35"H x 78 5/8" perimeter
- Accommodates 25" diameter bags



LH-2001

- Overall size: 35"H x 25" diameter
- Accommodates 25" diameter bags



820 South Mulberry Street
Millstadt, IL 62260

Toll Free: 1-877-828-9975

info@macmedical.com

www.macmedical.com

